

DEC
2008

 **Fenner Drives®**



PowerMax™
PULLEYS & IDLERS

PowerMax™

PULLEYS & IDLERS

The PowerMax Advantage.....	4
Technical Data	
Material.....	6
Bearings & Bearing Life.....	6
V-Belt Idlers.....	7
Single Flange Idlers.....	7
Flat Belt Idlers.....	8
Round Belt Idlers.....	9
Cable Pulleys.....	9
Sprockets.....	10
Carriage Rollers.....	10
Mounting Adapters.....	11
DriveN Pulleys.....	12
Custom Solutions.....	13
T-Max Belt & Chain Tensioners®.....	14



Composite Idlers & Sprockets

Fenner Drives is the industry leader in composite products for industrial power transmission and material handling applications. The PowerMax™ line of idler pulleys and sprockets offer superior composite design for years of successful service. PowerMax Idler Pulleys and Sprockets are available in a wide range of sizes for flat, round and V-belts and industry standard pitch chains. They are perfect for use as high-speed idlers on conveyors, packaging equipment, lawn and garden equipment, floor cleaning machines and in many other power transmission applications. The use of high-strength glass-reinforced nylon makes our pulleys and sprockets ideal for washdown applications and corrosive environments (special bearings available for harsh environments — consult factory).

High quality materials are used in our products to ensure years of service even in the toughest surroundings. Fenner Drives also has in-house engineering to help you design a custom idler pulley or sprocket for your application. Our modular tooling systems allow us to build tools that fit your budget and your production lead time requirements.

Combine PowerMax Composite Idlers and Sprockets with our T-Max automatic linear and rotary tensioners for an “off the shelf” tensioning solution.



Technical Help and Ordering

www.fennerdrives.com

North American Sales Office

1-800-243-3374

1-717-665-2421

European Sales Office

+44(0) 870 7577007

+44(0) 113 2493486

PowerMax™

PULLEYS & IDLERS

The PowerMax Advantage...



- Molded of high-strength glass-reinforced nylon
- Increased cable or belt life vs. steel or cast iron
- Precision sealed bearings are greased for life — never need relubrication

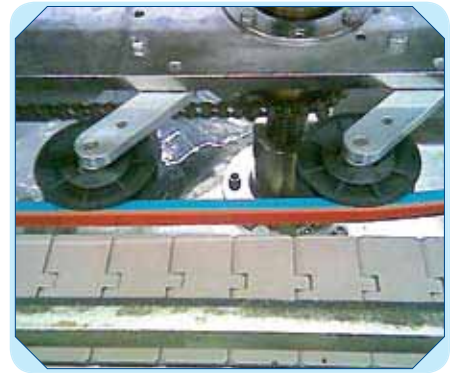

- Ultra smooth belt groove surface for quiet operation
- Corrosion resistant — perfect for washdown applications (stainless steel bearings are available in many sizes for severe applications)
- Pre-installed mounting adapters convert bearings to standard shaft/bolt sizes



Photo courtesy of Vectra Fitness

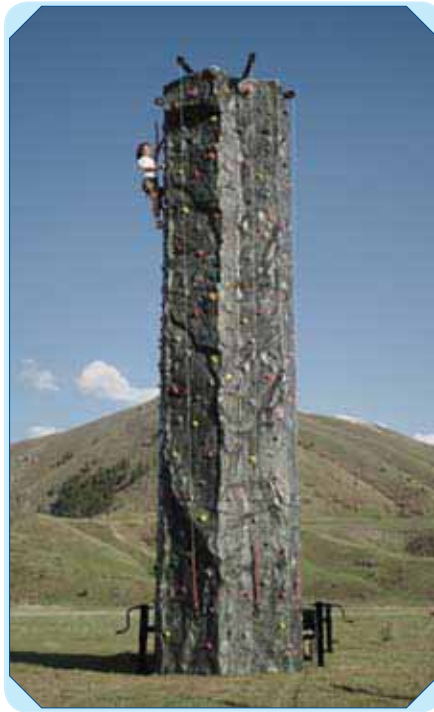

- Lighter-weight composite design means less energy for start up and running
- All catalog items are in stock for immediate shipment
- Available in a wide range of sizes for flat, round and V-belts
- Special sizes are easy with Fenner Drives' Modular Mold System
- Over 20 years of experience in composite part designs

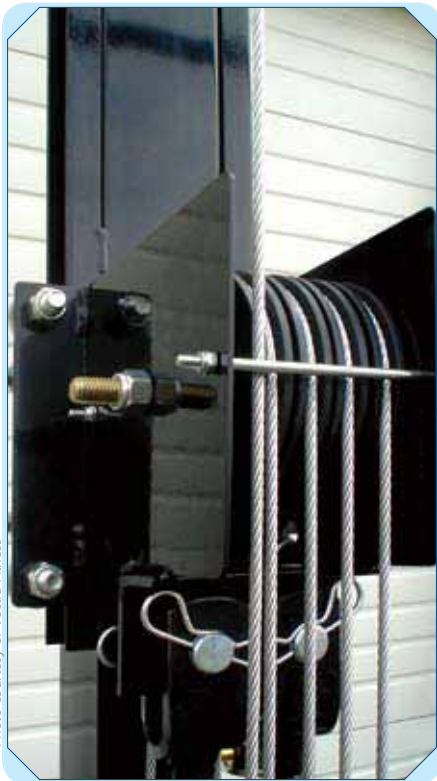

Photo courtesy of Vectra Fitness

- State-of-the-art precision molding assures consistent quality parts
- Designed using Finite Element Analysis (FEA) to ensure superior product performance
- Stringent product testing and quality checks ensure that you only get the best products for years of dependable service



Technical Data

About Our Material

Fenner Drives uses engineering composites, which ensure the highest level of performance and consistent strength. Our standard material is 33% glass reinforced nylon 6/6. The combination of high strength, temperature resistance and abrasion resistance makes nylon a versatile engineering thermoplastic.

MATERIAL PROPERTIES		
33% GLASS-REINFORCED NYLON 6/6, dry as molded		
Property	ASTM Code	Value
Tensile Strength at Break	D638	20,000 psi
Flexural Modulus	D790	1,300,000 psi
Heat Deflection Temp @ 264 psi	D648	480°F (249°C)
Continuous Service Temp. (Min. – Max.)	-	32° – 225°F (0° – 107°C)
Izod Impact Strength (notched 1/8")	D256	1.3 – 1.8 ft.-lb/in. of notch
Water Absorption (24 hour immersion)	D570	0.7%

Note: Data listed was generated using molded specimens tested under standard conditions. Many of the mechanical properties can be influenced by processing conditions, environmental factors and the application of stress. Therefore, this data characterizes typical production material, and should not be used either to establish specification limits or alone as the basis for engineering design.

About Our Bearings

Almost all PowerMax™ Pulleys use precision 6203-2RS chrome-alloy steel radial ball bearings (exceptions are noted). These bearings meet all ABEC-1 standards. Our bearings utilize two rubber wiping seals to keep the grease in and contaminants out. See chart for standard load ratings.

BEARING PROPERTIES
Type: 6203-2RS
Seals: Rubber Wiping
Fit: ABEC-1 "C4" Internal Clearance
Lubrication: Chevron SRI #2 or equivalent (30% ± 5% Fill)
Service Temperature: -20° – 350°F (-30° – 180°C)
Basic Dynamic Load: 1660 lbs. (7384N)

6203 RADIAL LOAD RATINGS											
Speed (RPM)	33	100	200	300	500	1000	1500	1800	2500	3600	5000
Load (lbs)	1660	1150	915	795	670	535	465	440	395	350	310
Load (N)	7384	5115	4070	3536	2980	2380	2068	1957	1757	1557	1379

Load Ratings based on 500 HR minimum L₁₀ life.

Bearing Life

How long a bearing will last in an application depends on two variables: first, the bearing's physical properties (material, design, method of manufacture); and second, the conditions of operation (load, speed, temperature, lubrication). Although it is not possible to predict the exact life of a bearing, the designer can calculate the "L₁₀ Life" of a bearing. L₁₀ is the life, in hours or revolutions, that 90% of a group of bearings will complete or exceed. The equations for calculating L₁₀ life are:

- Revolutions: $L_{10} = \left(\frac{C}{P}\right)^3 \times 10^6$

- Hours: $L_{10} = \left(\frac{C}{P}\right)^3 \times \frac{16667}{N}$

- Where:

L₁₀ = Rating Life

C = Basic Dynamic Capacity

P = Radial Load in lbs.

N = Speed in RPM

V-Belt Idlers

PowerMax™ V-Belt Idlers are designed for strength and durability. For use with standard A, B and 5V section belts in a variety of industrial applications. The use of radial supporting ribs provides additional belt support and prevents groove deformation. Ideal for use with Fenner Drives Rotary Tensioners. Mounting adapters are available to facilitate easy installation (see page 11).

NOTES:

Pulley diameters can be machined down below the pitch line of belt for material handling applications.

† Insertion molded bearing.

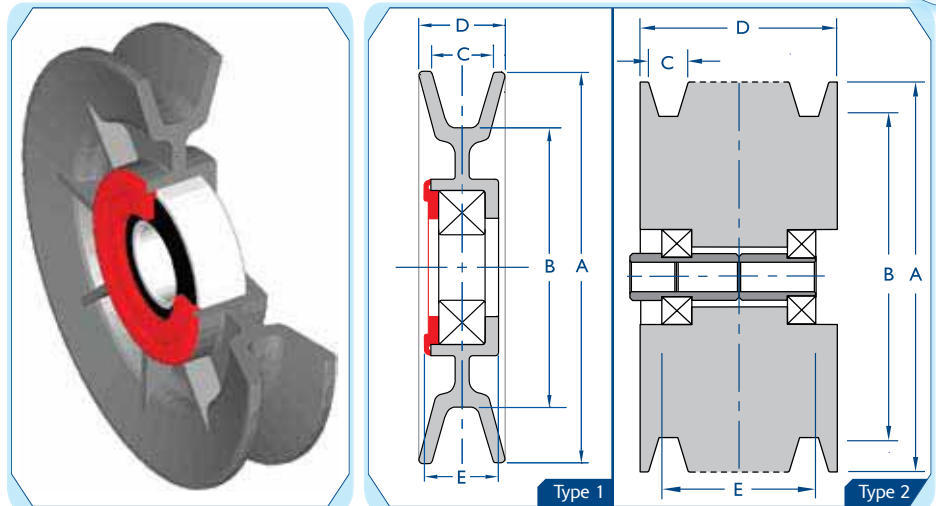

Part Number	Type	Grooves	DIMENSIONS					Belt Size	Bearing Type	Bore Size
			A	B	C	D	E			
VA3001	1	1	3.00	2.00	.50	.70	.76	A	6203-2RS	17mm
VA3002	1	1	3.10	1.84	.63	.78	.78	B	6203-2RS	17mm
VA4001	1	1	3.98	2.99	.50	.70	.78	A	6203-2RS	17mm
VA4002	1	1	4.00	2.84	.64	.86	.76	B	6203-2RS	17mm
VA5001	1	1	5.04	3.84	.65	.80	.78	B	6203-2RS	17mm
VA6001	1	1	6.03	5.12	.50	.72	.76	A	6203-2RS	17mm
VA6250†	1	1	6.25	5.00	.61	.95	.67	A/B	6203-2RS	17mm
VA7501	1	1	7.50	6.60	.54	.72	.71	A	6203-2RS	17mm
V2B6280	2	2	6.28	5.18	.64	1.72	1.72	B/5V	6203-2RS	.510/.520
V3B6280	2	3	6.28	5.18	.64	2.44	2.44	B/5V	6203-2RS	.510/.520
V4B6280	2	4	6.28	5.18	.64	3.16	3.16	B/5V	6203-2RS	.510/.520

Single Flange Idlers

PowerMax Single Flange Idlers are designed specifically for use on conveyor corners but can be used for a variety of applications. Designed for use with B-section V-belts. Mounting adapters are available to facilitate easy installation (see page 11).

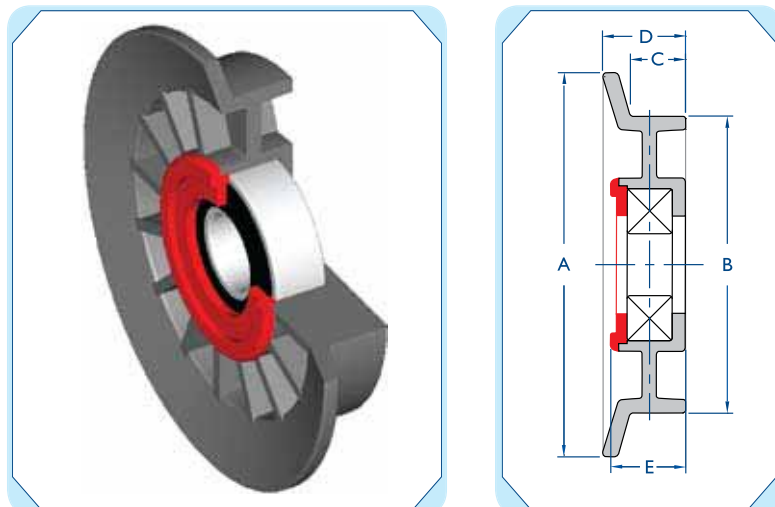

Part Number	A	DIMENSIONS			E	Belt Size	Bearing Type	Bore Size
		B	C	D				
VA3600	3.60	2.84	.59	.84	.79	B	6203-2RS	17mm
VA4130	4.13	3.23	.58	.86	.78	B	6203-2RS	17mm

NOTE: All dimensions are for reference only.

Flat Belt Idlers

PowerMax™ Flat Belt Idlers are available for a wide range of standard belt sizes. Also suitable for use as back side idlers on V-belts. Our molded-in crown helps center the belt and prevent rubbing against flanges. Mounting adapters are available to facilitate easy installation (see page 11).

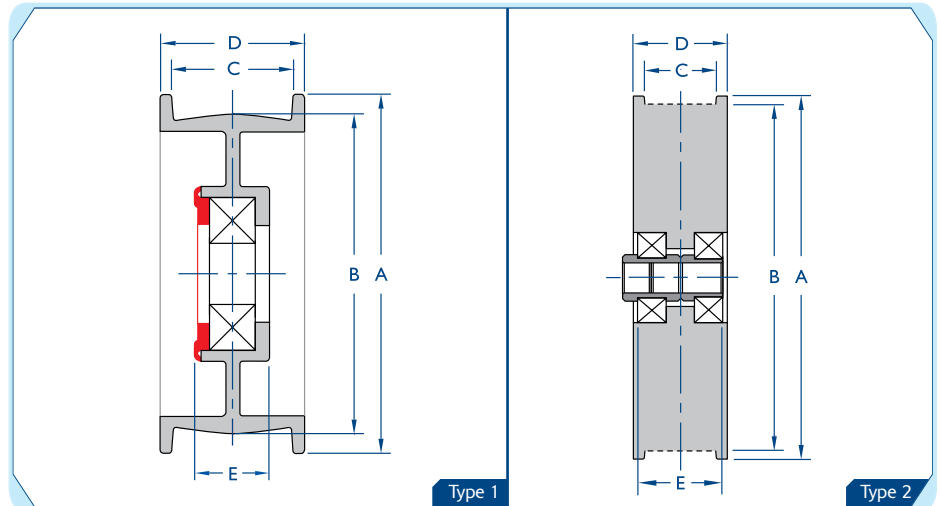
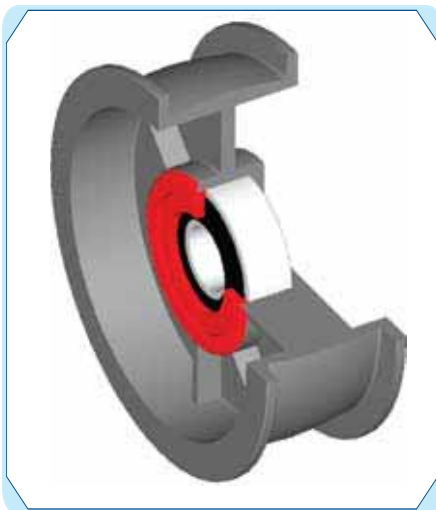

Part Number	Type	Crown	DIMENSIONS					Belt Size	Bearing Type	Bore Size
			A	B	C	D	E			
FA2001†	1	YES	2.07	1.88	1.37	1.54	.47	1 ³ / ₈ "	6203-2RS	17mm
FA2002†	1	YES	2.35	1.99	.98	1.15	.47	7/ ₈ "	6203-2RS	17mm
FA2003	1	NO	2.76	1.94	.82	1.15	.75	1 ³ / ₁₆ "	6203-2RS	17mm
FA2009*†	1	NO	N/A	2.00	1.00	N/A	.47	1"	6203-2RS	17mm
FA2010*†	1	NO	N/A	1.98	.75	N/A	.47	3/ ₄ "	6203-2RS	17mm
FA2501†	1	NO	2.48	1.97	1.55	1.85	.72	1 ¹ / ₂ "	6203-2RS	17mm
FA2700*†	1	NO	N/A	2.71	1.05	N/A	.67	1"	6203-2RS	17mm
FA2750†	1	YES	2.75	1.97	1.09	1.40	.67	1"	6203-2RS	17mm
FA2751	1	YES	2.75	2.52	1.00	1.22	.80	1"	6203-2RS	17mm
FA2900*	1	YES	N/A	2.91	1.22	N/A	.76	1 ¹ / ₈ "	6203-2RS	17mm
FA3002	1	YES	3.00	2.50	1.02	1.31	.76	1"	6203-2RS	17mm
FA3003*	1	NO	N/A	2.96	1.09	N/A	.76	1"	6203-2RS	17mm
FA3250*†	1	NO	N/A	3.20	1.01	N/A	.67	1"	6203-2RS	17mm
FA3251†	1	YES	3.24	2.97	1.04	1.20	.67	1"	6203-2RS	17mm
FA3301	1	YES	3.38	2.97	1.38	1.67	.78	1 ¹ / ₄ "	6203-2RS	17mm
FA3501	1	YES	3.50	3.00	.77	1.09	.76	3/ ₄ "	6203-2RS	17mm
FA3502	1	YES	3.50	3.00	1.00	1.22	.76	1"	6203-2RS	17mm
FA3504	1	YES	3.48	2.98	.69	.90	.76	1 ¹ / ₁₆ "	6203-2RS	17mm
FA3750†	1	YES	3.75	2.96	1.09	1.38	.67	1"	6203-2RS	17mm
FA3751†	1	YES	3.80	3.25	1.03	1.24	.67	1"	6203-2RS	17mm
FA4501	1	YES	4.50	4.00	1.09	1.39	.76	1"	6203-2RS	17mm
FA4502*	1	NO	N/A	4.50	1.21	N/A	.82	1 ³ / ₁₆ "	6203-2RS	17mm
FA4750†	1	YES	4.75	3.96	1.09	1.38	.67	1"	6203-2RS	17mm
FA5501†	1	YES	5.56	5.03	1.02	1.29	.72	1"	6203-2RS	17mm
FA5504†§	1	NO	5.72	5.40	1.08	1.37	1.25	1"	6203-2RS	17mm
FX0001‡	1	YES	2.75	2.37	1.07	1.39	N/A	1"	6205-2RS	1"
FX0002*‡	1	YES	N/A	2.33	1.39	N/A	N/A	1 ³ / ₈ "	6205-2RS	1"
F1B6280	2	NO	6.28	6.00	1.22	1.63	1.63	1"	6203-2RS	.510/.520
F2B6280	2	NO	6.28	6.00	2.10	2.50	2.50	2"	6203-2RS	.510/.520
F3B6280	2	NO	6.28	6.00	2.91	3.31	3.31	2 ³ / ₄ "	6203-2RS	.510/.520
F4B6280	2	NO	6.28	6.00	3.85	4.25	4.25	3 ³ / ₄ "	6203-2RS	.510/.520

NOTES:

Flat belt pulleys are available without flanges or crown. Contact factory for details.

* These items are standard without flanges.

† Insertion molded bearing.

‡ FX0001 and FX0002 use a special 1" bore bearing with extended inner-race.

§ This item has two 6203-2RS bearings. Please consult your Inside Sales Specialist when ordering with adapters.

All dimensions are for reference only.

Round Belt Idlers

PowerMax™ Round Belt Idlers are designed for use with round belts, ropes or cables. The deep uninterrupted groove provides continuous support and eliminates any binding or wedging problems found with steel or cast iron pulleys. Small series pulleys use a special 6902-2RS bearing and are ideal for tight-fit applications. Mounting adapters are available to facilitate easy installation (see page 11).

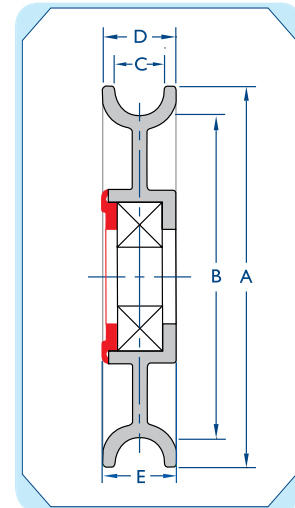
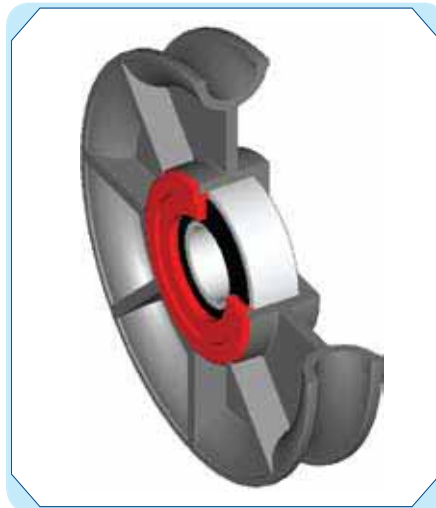

Part Number	DIMENSIONS					E	Radius	Maximum Cable Size	Bearing Type	Bore Size
	A	B	C	D						
RA3001	3.05	2.45	.40	.61	.81	.19	3/8"	6203-2RS	17mm	
RA3002	3.05	2.45	.42	.61	.63	.21	13/32"	6203-2RS	17mm	
RA3501	3.50	2.75	.53	.76	.76	.26	1/2"	6203-2RS	17mm	
RA3502	3.50	2.75	.44	.76	.76	.19	3/8"	6203-2RS	17mm	
RA4101	4.12	3.50	.53	.68	.72	.26	1/2"	6203-2RS	17mm	
RA4801	4.80	4.00	.53	1.00	.77	.28	1/2"	6203-2RS	17mm	
RA4802	4.82	4.00	.75	1.06	.77	.36	11/16"	6203-2RS	17mm	
RA5502†	5.50	4.62	.38	.56	.70	.19	3/8"	6203-2RS	17mm	
SMALL SERIES										
RA1850†	1.84	1.39	.44	.62	.48	.16	5/16"	6902-2RS	15mm	
RA2540	2.54	1.90	.44	.63	.63	.16	5/16"	6902-2RS	15mm	

NOTES:

Small series pulleys cannot accept mounting adapters. Contact factory for special options.

Cable Pulleys

Molded in our premium glass-reinforced nylon, PowerMax Pulleys can be used with both coated and uncoated cable and will provide a substantial increase in cable life over steel or aluminum pulleys. Our cable pulleys feature a non-ribbed, solid web construction for strength and appearance and are perfect for a variety of cable applications. Mounting adapters are available to facilitate easy installation (see page 11).

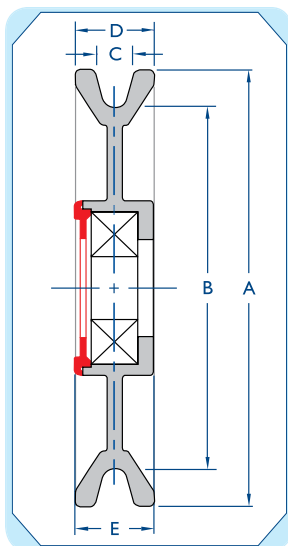

Part Number	DIMENSIONS					E	Maximum Cable Size	Bore Size
	A	B	C	D				
RA2701	2.75	2.43	.23	.54	.82	5/32"	17mm	
RA3503†	3.55	2.73	.39	.80	.77	1/4"	17mm	
RA3504	3.50	2.81	.31	.65	.77	7/32"	17mm	
RA4501†	4.46	3.74	.38	.86	.77	1/4"	17mm	
RA4502†	4.46	3.74	.38	.86	.77	3/16"	17mm	
RA5001	5.00	4.31	.31	.65	.73	3/16"	17mm	
RA5501†	5.50	4.86	.22	.53	.60	5/32"	17mm	
RA6001	6.00	5.20	.40	.80	.80	1/4"	17mm	

NOTES:

† Insertion molded bearing.

All dimensions are for reference only.

Sprockets

- Wear resistant glass-reinforced nylon
- Insertion molded ABEC-1 high precision bearings
- Lightweight and quiet
- Corrosion resistant
- Lubrication not required
- Mounting adapters are available to facilitate easy installation (see page 11).
- Ideal for use with T-Max Linear and Rotary Tensioners

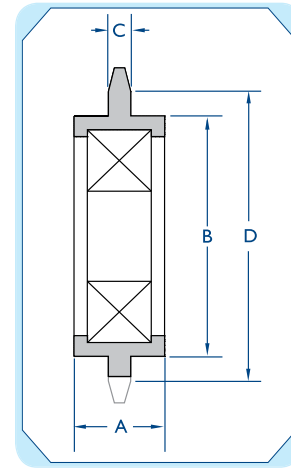

Part Number	Chain #	# Teeth	Nominal O.D. (in.)	Pitch Diameter	DIMENSIONS			Bearing Type	Bore Size
					A	B	C		
CS3502	35	19	2.48	2.28	.67	1.78	.164	6203-2RS	17mm
CS4002	40	17	2.98	2.72	.67	1.78	.279	6203-2RS	17mm
CS4003	40	17	2.98	2.72	.67	1.78	.279	6203-2RS-10	5/8"
CS4006	40	17	2.98	2.72	.67	1.78	.279	6203-2RS-12	3/4"
CS5002	50	15	3.36	3.01	.67	1.78	.343	6203-2RS	17mm
CS5004	50	15	3.36	3.01	.67	1.78	.343	6203-2RS-10	5/8"
CS5005	50	15	3.36	3.01	.67	1.78	.343	6203-2RS-12	3/4"
CS6002	60	13	3.49	3.14	.67	1.78	.449	6203-2RS	17mm
CS6003	60	13	3.49	3.14	.67	1.78	.449	6203-2RS-10	5/8"
CS6004	60	13	3.49	3.14	.67	1.78	.449	6203-2RS-12	3/4"
CS8002	80	12	4.40	3.86	.67	1.78	.58	6203-2RS	17mm
CS8003	80	12	4.40	3.86	.67	1.78	.58	6203-2RS-10	5/8"
CS8004	80	12	4.40	3.86	.67	1.78	.58	6203-2RS-12	3/4"

Carriage Rollers

- Designed for higher loads in low RPM applications
- Precision and semi-precision ball bearings for varying load requirements
- Designed to roll smoothly on round rails
- Molded nylon construction for quiet operation
- Internal spacer allows full tightening without binding (RX0219 only)

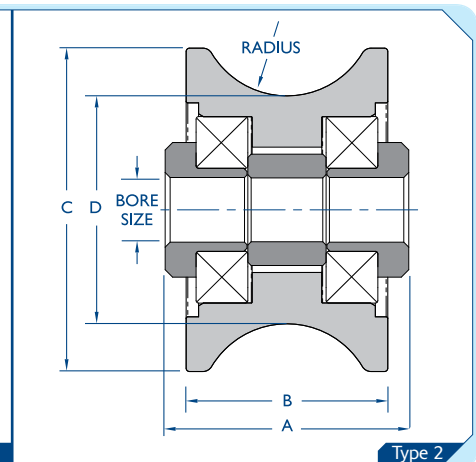
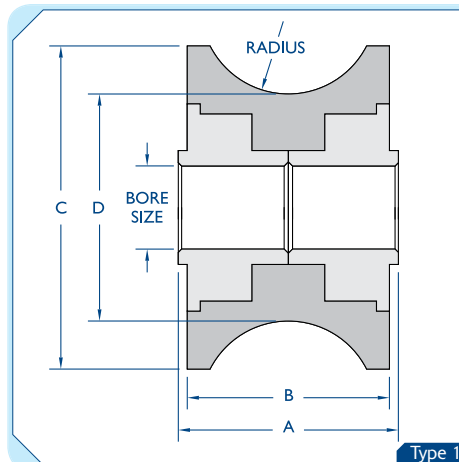

Part Number	Type	A	DIMENSIONS			Radius Inches	Bore Size
			B	C	D		
RA2001	1	1.36	1.20	1.95	1.37	.53	3/8"
RA2002	1	1.36	1.20	1.95	1.37	.53	1/2"
RA2004	1	1.48	1.20	1.95	1.37	.53	1/2"
RX0219	2	1.48	1.20	1.95	1.38	.53	3/8"

When installing RA2001, RA2002, or RA2004, the inner race of the bearings must be free to move in the mounting arrangement – they must not be clamped tight. For more information on mounting carriage rollers, please contact our applications engineering group.

NOTE: All dimensions are for reference only.

Mounting Adapters

Versatile mounting adapters simplify the job of assembly and help to reduce overall cost. Made of high quality sintered iron materials, they are press-fitted in place at the factory so that you only need to handle one component — the “finished” belt idler assembly. The three standard types are available to fit a 17mm bore bearing, in a choice of widths and bore sizes to meet most mounting requirements. However, our flexible tooling approach allows specials to be produced quickly and economically, frequently with little or no tooling charge.

Bore Reducing Adapters

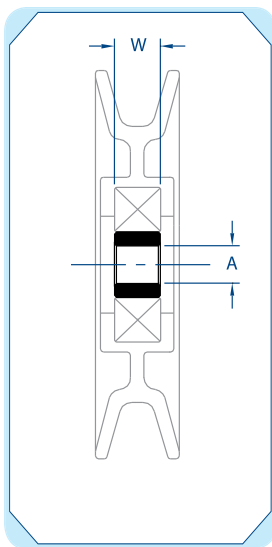

Clevis Adapters

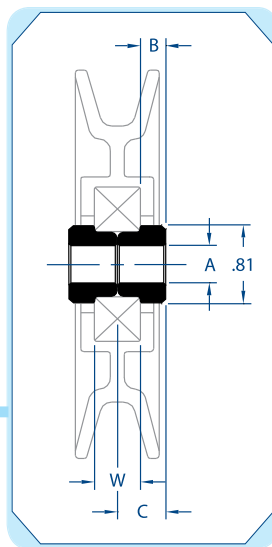

Shoulder Adapters

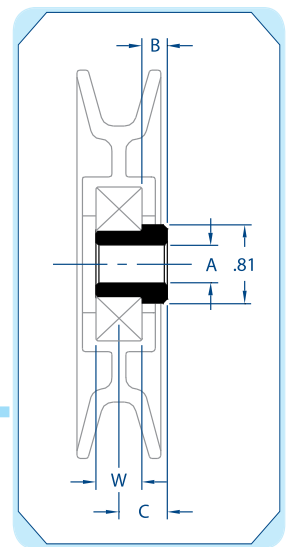

Part Number	DIMENSIONS	
	A	W
RB0001	.385 / .395	.472
RB0002	.510 / .520	.472
RB0071	.474 / .486	.472

Part Number	DIMENSIONS			
	A	B	W	C
CB0001	.385 / .395	.26	.472	.50
CB0002	.385 / .395	.51	.472	.75
CB0003	.385 / .395	.76	.472	1.00
CB0004	.510 / .520	.26	.472	.50
CB0005	.510 / .520	.51	.472	.75
CB0006	.510 / .520	.76	.472	1.00
CB0013	.385 / .395	.08	.472	.32
CB0015	.314 / .324	.08	.472	.32
CB0016	.385 / .395	.17	.472	.41
CB0020	.314 / .324	.10	.472	.34
CB0023	.394 / .399	.64	.472	.87
CB0036	.385 / .395	.70	.472	.94
CB0058	.385 / .395	.33	.472	.57
CB0100	.397 / .407	.26	.472	.50

Part Number	DIMENSIONS			
	A	B	W	C
SB0001	.385 / .395	.26	.472	.50
SB0002	.385 / .395	.51	.472	.75
SB0003	.385 / .395	.76	.472	1.00
SB0004	.510 / .520	.26	.472	.50
SB0005	.510 / .520	.51	.472	.75
SB0006	.510 / .520	.76	.472	1.00
SB0013	.385 / .395	.15	.472	.38
SB0016	.385 / .395	.11	.472	.35
SB0017	.385 / .395	.48	.472	.72
SB0018	.385 / .395	.40	.472	.64
SB0019	.385 / .395	.55	.472	.79
SB0020	.385 / .395	.59	.472	.83
SB0032	.385 / .395	.56	.472	.80
SB0052	.385 / .395	.71	.472	.95
SB0033	.385 / .395	.95	.472	1.19
SB0090	.255 / .265	.31	.472	.55

NOTES:

All dimensions are for reference only.
Consult factory for metric availability.

DriveN Pulleys

The latest innovation in composite power transmission components from Fenner Drives.

- For use with A/4L section V-belts
- Directly interchangeable with industry standard "AK" type pulleys
- Molded premium quality glass-reinforced nylon material
- Sintered metal drive hub insertion molded for high strength
- Corrosion resistant and lightweight
- State-of-the-art precision molding assures part consistency
- Highly cost effective
- Bore sizes:
5/8", 3/4", 7/8", 1"

Shaft Size	Keyseat
5/8", 3/4", 7/8"	3/16" x 3/32"
1"	1/4" x 1/8"

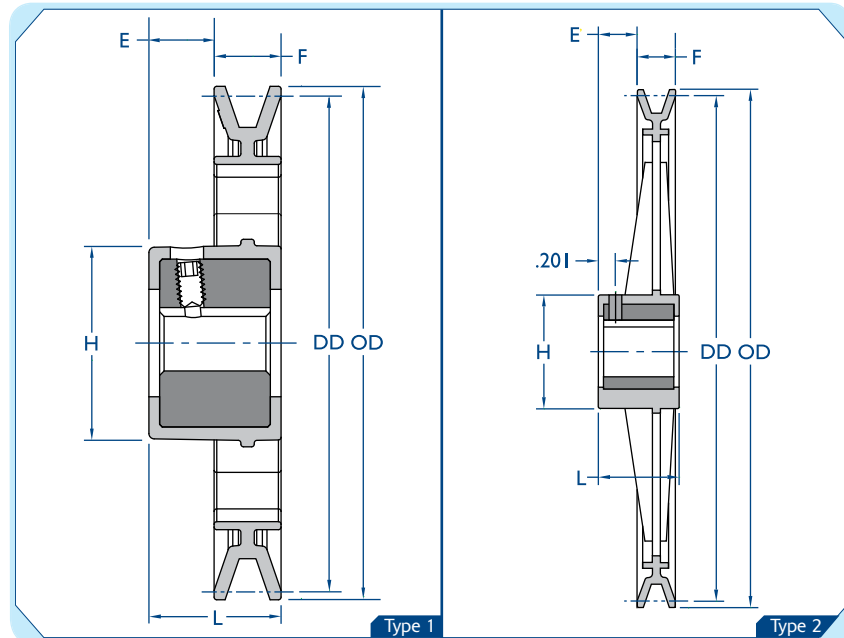

Part Number	Type	DIMENSIONS				Belt Size	DIAMETER		Number Spokes	Spoke Style
		E	F	H	L		Outside	Datum		
AFD44	1	.79	.74	2.17	1.53	A/4L	4.25	4.00	-	-
AFD49	1	.79	.74	2.17	1.53	A/4L	4.75	4.50	4	I-Beam
AFD59	1	.79	.74	2.17	1.53	A/4L	5.75	5.50	4	I-Beam
AFD74	1	.79	.74	2.17	1.53	A/4L	7.25	7.00	4	I-Beam
AFD84	2	.78	.75	2.22	1.60	A/4L	8.25	8.00	6	Cross
AFD94	2	.78	.75	2.22	1.60	A/4L	9.25	9.00	6	Cross
AFD104	2	.78	.75	2.22	1.60	A/4L	10.25	10.00	6	Cross
AFD112	2	.78	.75	2.22	1.60	A/4L	10.98	10.73	6	Cross
AFD124	2	.78	.75	2.22	1.60	A/4L	12.25	12.00	6	I-Beam



NOTES:

All dimensions are for reference only.
Consult factory for availability.

Fenner Drives® Custom Solutions



Since 1983, Fenner Drives has been developing innovative product design solutions for the Original Equipment Manufacturer (OEM). Our customer-driven approach brings together the latest in product design and manufacturing technology with years of experience as the leading producer of composite power transmission components.

Once we understand your specific application, our engineers develop a “conceptual” design for your review. This design is then optimized using the latest in engineering CAD software. Once qualified, state-of-the-art computer aided manufacturing processes are used to produce both molding tools and finished parts accurately and economically in-house.

Our corrosion resistant, lightweight composite designs are not only developed to embody high strength and long service life, but also to reduce component costs in comparison to equivalent metallic parts.



Belt & Chain Tensioners



**Automatically
take up the slack.**

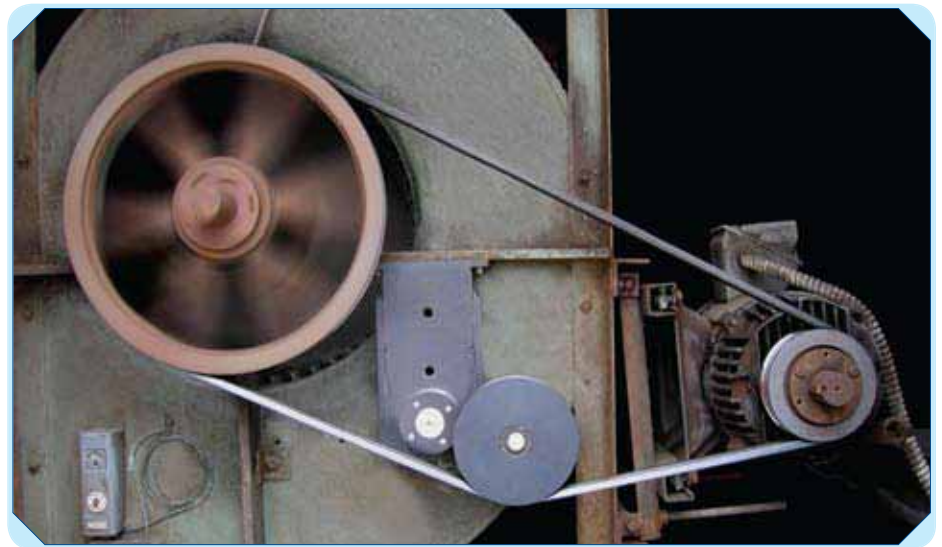

As more and more customers demand maintenance-free systems, T-Max Belt Tensioners from Fenner Drives can provide an optimum automatic solution for “hands off” field performance.

- Rugged die-cast aluminum housings
- Constructed with alloy steel springs
- Stainless components available for washdown applications
- Sintered bronze, oil-impregnated bearings
- No exposed rubber elements to stretch and cold-flow
- Single bolt mounting and graduated scale tension adjustment



Combined with an idler pulley or chain sprocket from Fenner Drives, an automatic T-Max Tensioner can be used to:

- Maintain correct belt and chain tension
- Extend the life of critical drive components
- Reduce system downtime
- Increase drive efficiency
- Reduce belt and chain whip on long center drives
- Ensure drive components do not snag obstructions
- Reduce resonant frequency of chain drives



RT1000 on an agricultural sprayer



RT1000 on a centrifugal fan



RT4100 on a live roller conveyor system

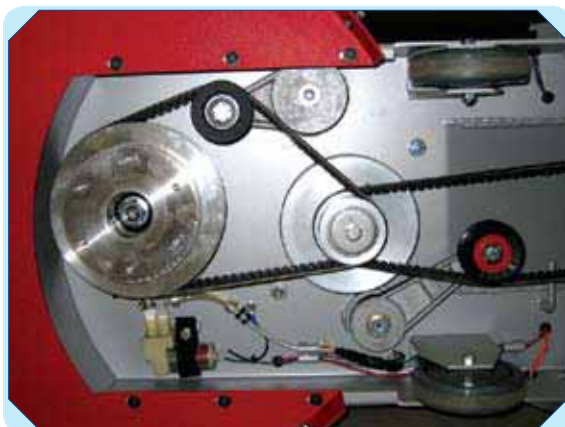

RT1000 & RT1600 on the undercarriage of a floor cleaner



RT4100 on a prop fan

Count on Fenner Drives.

We've got the right product for your application.



EAGLE
POLYURETHANE BELTING & O-RINGS

PowerTwist Plus
V-BELTS

SUPER T LINK
SP WEDGE BELTS

NU T LINK
V-BELTS

T-MAX
BELT & CHAIN TENSIONERS

PowerMax
PULLEYS & IDLERS

B-LOC
KEYLESS BUSHINGS

Trantorque
Keyless Bushings

Trackstar
UHMW BELT & CHAIN GUIDES

Fenner Drives is a proven leader in the design and manufacture of problem-solving power transmission and motion transfer components. Recognized widely for our expertise and innovation in manufacturing technology, we consistently blend reliability, quality and value in our products. Our ISO 9001:2000 certified production facilities are located in Manheim, PA; Wilmington, NC; and Leeds, UK. As part of our commitment to provide unsurpassed technical support and service, we maintain extensive engineering, development and testing facilities.

Visit us at www.fennerdrives.com

 **Fenner Drives**
an ISO 9001:2000 certified company

311 West Stiegel Street
Manheim, PA 17545-1747

www.fennerdrives.com
TEL: 800-243-3374
TEL: 717-665-2421
FAX: 717-665-2649

Hudson Road
Leeds, LS9 7DF UK

www.fennerdrives.com
TEL: +44 (0)870 7577007
TEL: +44 (0)113 2493486
FAX: +44 (0)113 2489656